

**Please note**

This drawing is not to full scale. Therefore, do not use it as your template to locate the hole positions while you fabricate your door and frame for the installation of this product. Instead, make the measurements needed manually without the use of the enclosed template which is not to full scale.

**A Type REGULAR ARM (PULL SIDE) Mounting**

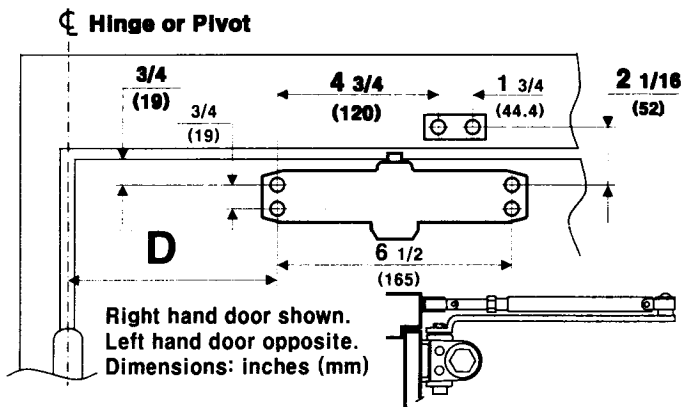

MODEL	D
71, 171, 510, 1510, 610, 1610 72, 172, 520, 1520, 620, 1620	2 7/16 (62)
73, 173, 530, 1530, 630, 1630 74, 174, 540, 1540, 640, 1640	3 9/16 (90)

**INSTALLATION INSTRUCTIONS**

1. Use dimensions shown beside, mark FORE (4) HOLES ON DOOR for door closer and TWO (2) HOLES ON FRAME for arm shoe.
2. Drill pilot holes in door and frame for #14 all-purpose screws or drill and tap for 1/4-20 machine screws.
3. Install adjustable forearm/arm shoe to frame using screws provided.
4. Mount closer on door using screws provided. **SPEED ADJUSTING VALVE MUST BE POSITIONED TOWARD HINGE EDGE.**
5. Install main arm to top pinion shaft, perpendicular to door as shown below. Secure tightly with arm screw/washer assembly provided.
6. Adjust length of forearm so that forearm is perpendicular to frame when assembled to preloaded main arm (Illustration below). Secure forearm to main arm with screw/washer assembly provided.
7. Adjust closing speed of door.
8. Snap pinion cap over shaft at bottom of closer.

**B Type TOP JAMB (PUSH SIDE) Mounting**

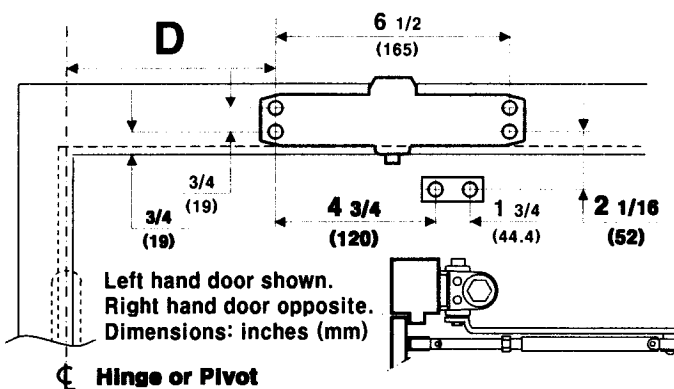

MODEL	D
71, 171, 510, 1510, 610, 1610 72, 172, 520, 1520, 620, 1620	2 7/16 (62)
73, 173, 530, 1530, 630, 1630 74, 174, 540, 1540, 640, 1640	3 9/16 (90)

**INSTALLATION INSTRUCTIONS**

1. Use dimensions shown beside, mark FORE (4) HOLES ON FRAME for door closer and TWO (2) HOLES ON DOOR for arm shoe.
2. Drill pilot holes in door and frame for #14 all-purpose screws or drill and tap for 1/4-20 machine screws.
3. Install adjustable forearm/arm shoe to door using screws provided.
4. Mount closer on frame using screws provided. **SPEED ADJUSTING VALVE MUST BE POSITIONED TOWARD HINGE EDGE.**
5. Install main arm to top pinion shaft, perpendicular to door as shown below. Secure tightly with arm screw/washer assembly provided.
6. Adjust length of forearm so that forearm is perpendicular to frame when assembled to preloaded main arm (Illustration below). Secure forearm to main arm with screw/washer assembly provided.
7. Adjust closing speed of door.
8. Snap pinion cap over shaft at bottom of closer.

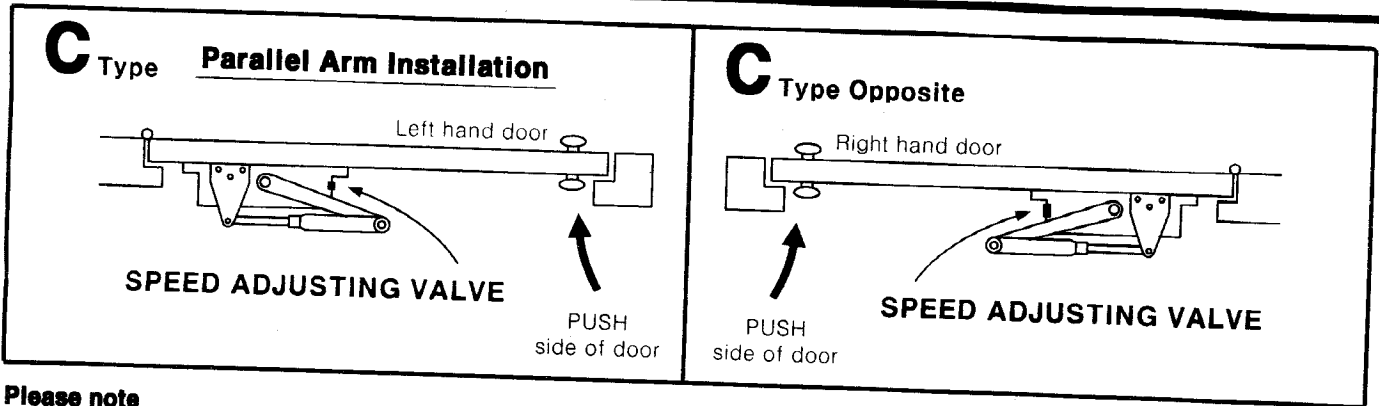

**Please note**

This drawing is not to full scale. Therefore, do not use it as your template to locate the hole positions while you fabricate your door and frame for the installation of this product. Instead, make the measurements needed manually without the use of the enclosed template which is not to full scale.

**C Type PARALLEL ARM (PUSH SIDE) Mounting**

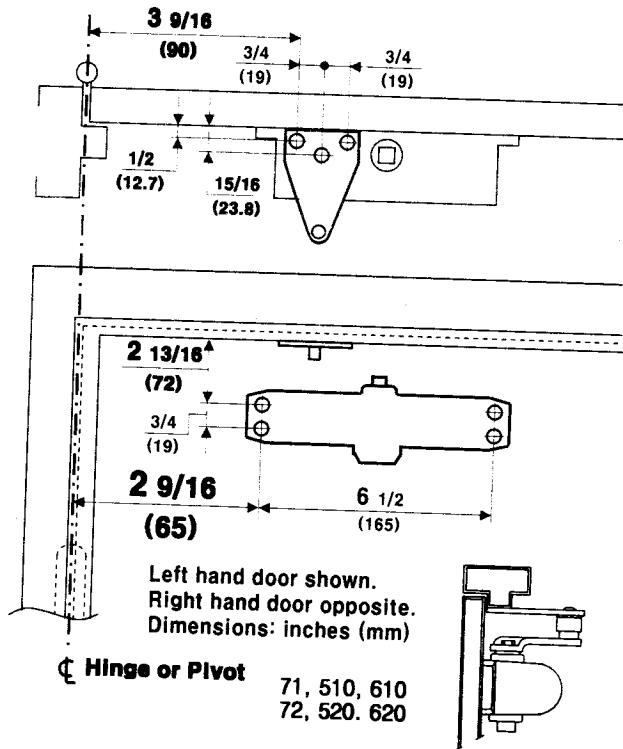

**INSTALLATION INSTRUCTIONS**

1. Use dimensions shown beside, mark FORE (4) HOLES ON DOOR for door closer and THREE (3) HOLES ON FRAME for parallel bracket.
2. Drill pilot holes in door and frame for #14 all-purpose screws or drill and tap for 1/4-20 machine screws.
3. Install Parallel Arm Bracket shoe to frame using screws provided.
4. Mount closer on door using screws provided. **SPEED ADJUSTING VALVE MUST BE POSITIONED TOWARD AWAY FROM HINGE EDGE.**
5. Install main arm to top pinion shaft, with arm pointing toward speed adjusting screw. Secure tightly with arm screw/washer assembly provided.
6. Remove arm shoe from fore arm and discard. Install ROD end of fore arm to bracket using screw/washer assembly provided. Adjust length of fore arm to set arm elbow approximately 3-3/8" (86mm) from door (refer to illustration below). Attach fore arm to main arm by rotating main arm away from door. Secure forearm to main arm using screw/washer assembly provided.
7. Adjust length of fore arm so when it is attached to main arm the main arm will be slightly away from parallel with closed door and assemble at elbow then tighten locknut.
8. Adjust door closing speed by speed adjusting valves.
9. Snap pinion cap over shaft at bottom of closer.

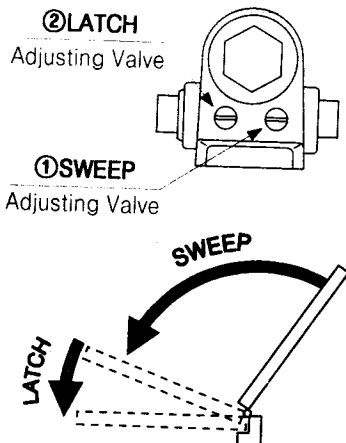

**CLOSING SPEED ADJUSTMENT**

**NOTE:** Closing arcs ("SWEEP" and "LATCH") are controlled by two (2) separate adjusting valves. Adjust the CLOSING speed first, then adjust the LATCHING speed.

- STEP 1.** "SWEEP" speed adjustment is accomplished by full rotation of the speed adjusting valve.
- Turn the speed adjusting valve **CLOCKWISE** for SLOWER CLOSE arc closing speed.
  - Turn the speed adjusting valve **COUNTER-CLOCKWISE** for a FASTER CLOSE arc closing speed.
- STEP 2.** "LATCH" speed adjustment is the same manner as "SWEEP" speed adjustment
- Turn the speed adjusting valve **CLOCKWISE** for SLOWER CLOSE arc closing speed.
  - Turn the speed adjusting valve **COUNTER-CLOCKWISE** for a FASTER CLOSE arc closing speed.

**CAUTION!!** Do not turn speed adjusting valve more than two (2) full turns counter-clockwise from factory set position, as two speed adjusting valves could become dislodged from the door closer body, resulting in the loss of internal fluid and failure of the device.